



INDUSTRIAL PRODUCTS DIVISION

Temperature Regulator I-1284-B through G Series (Bronze Valve Body)

GENERAL DESCRIPTION

The I-1284-B through G Series Temperature Regulators are compact, self-contained and self-powered, three-way control valves especially adaptable to control of water and lubricating oil temperatures on internal combustion engines. The POWER PILL® element, located inside the poppet assembly, responds to the temperature of the medium surrounding it and provides the force necessary to position the poppet as the temperature of the liquid passing through the valve changes. Temperature regulation is achieved by the proportional action of the three-way valve which varies the amount of medium through or bypassing the cooler to maintain the desired temperature. Operation of the POWER PILL elements is unaffected by pressure changes in the system.

The POWER PILLS are factory-set for the specified control temperature and are not manually adjustable. By exchange of POWER PILL elements, the operating temperature may be changed in a very simple manner. Since all internal parts lift out with the valve bonnet, it is not necessary to remove the valve from the piping.

The I-1284 series is equipped with a quick-acting manual operator which permits overriding the thermal element if and when abnormal load, conditions are encountered in the system.



SPECIFICATIONS

CONSTRUCTION

Valve Body Bronze, ASTM B62, with 150 lb. ANSI flanges.

Trim Cast brass with integral seating surfaces.

Packing Asbestos yarn Teflon* (suspensoid) treated rings.

Poppet Seal Split Buna-N "O"-ring (General Purpose, one red dot). Split Polyacrylate "O"-ring (Lube Oil Service, two blue dots).

NOTE: Unless otherwise specified, General Purpose Seal is installed at factory, with additional Lube Oil Seal packed with valve.

OPERATING RANGES: Available temperature ranges are tabulated below.

MAXIMUM VALVE BODY PRESSURE RATINGS:

2", 2 1/2", 3", 4"; 10.3 bar (150 psi) at 121° C. (250° F.). 5", 6"; 6.9 bar (100 psi) at 121° C. (250° F.).

PROOF PRESSURE: 10.3 bar (150 psi) at room temperature.

CAUTION: DO NOT EXCEED MAXIMUM TEMPERATURE/PRESSURE RATING.

DIMENSIONS See Figure 1.

SHIPPING WEIGHTS See Page 2.

*Dupont Company registered trademark.

I-1284 - SIZE		RANGE CODE	
CODE	SIZE	CODE	NORMAL OPERATING TEMPERATURE AT MIDSTROKE, °C. (°F.)
B	2"	18	49° (120°)
C	2 1/2"	1	54° (130°)
D	3"	15	60° (140°)
E	4"	4	66° (150°)
F	5"	5	68° (155°)
G	6"	10	71° (160°)
		11	74° (165°)
		12	77° (170°)
		21	79° (175°)
		13	82° (180°)
		8	85° (185°)
		17	88° (190°)
		23	93° (200°)
		SPECIAL	
		24	16° (60°)
		16	24° (75°)
		22	27° (80°)
		20	32° (90°)
		19	38° (100°)
		25	43° (110°)
		2	57° (135°)

NOTE: For cast steel valve body, refer to I-1284-P, Q, S, and T (Form No. P-2330).



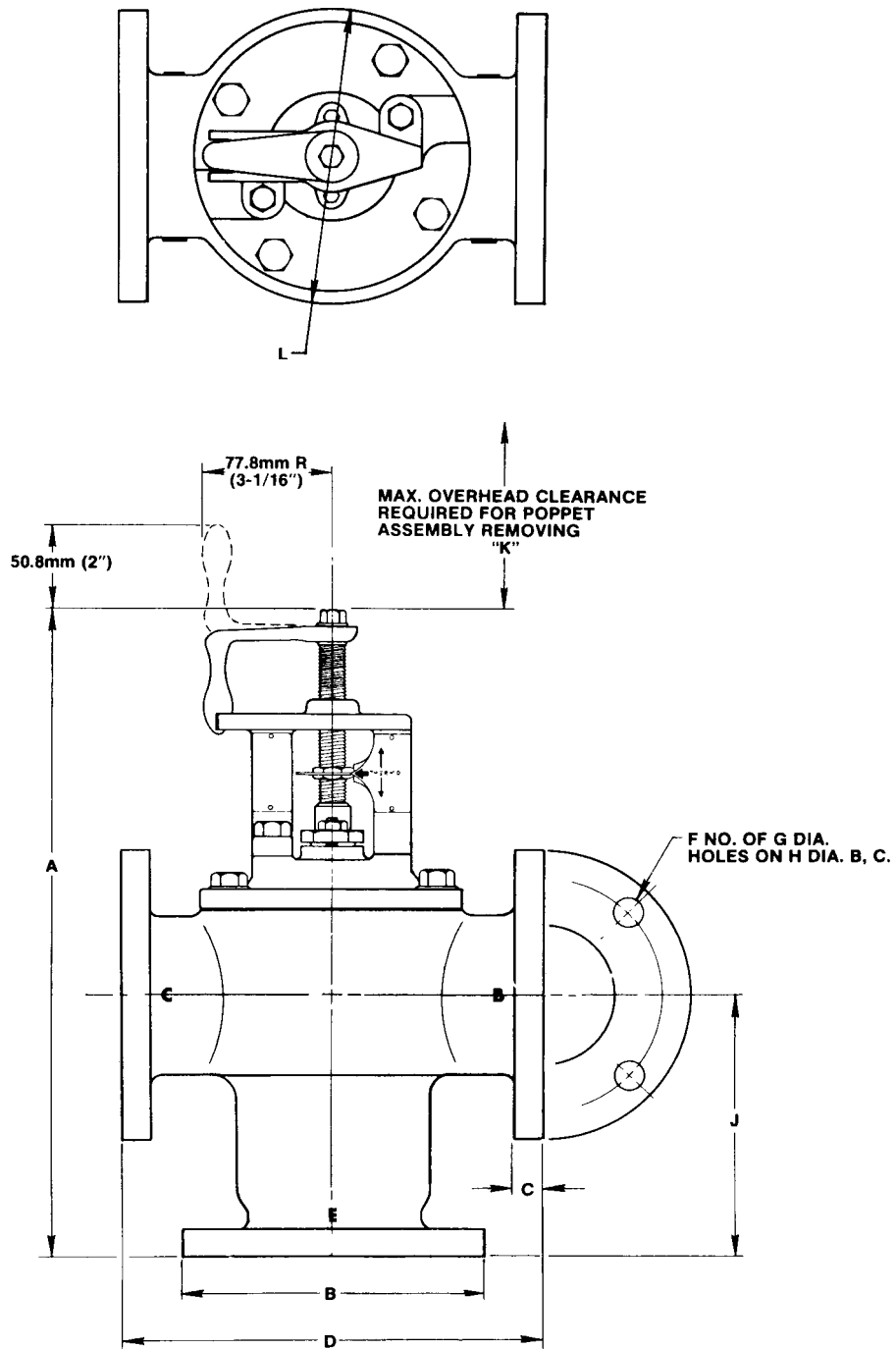

Figure 1

VALVE MODEL	SIZE	DIMENSIONS, mm										SHIPPING WGT., Kg
		A	g	C	D	F	G	H	J	K	L	
I-1284-B	2"	381	152	12.7	219	4	19.1	121	132	203	165	28
I-1284-C	2 1/2"	425	178	14.3	254	4	19.1	140	165	254	181	33
I-1284-D	3"	432	191	15.9	267	4	19.1	152	171	305	184	37
I-1284-E	4"	462	229	17.5	403	8	19.1	191	217	356	286	65
I-1284-F	5"	641	254	19.1	489	8	22.2	216	295	406	343	100
I-1284-G	6"	699	279	20.6	597	8	22.2	241	341	457	394	127

VALVE MODEL	SIZE	DIMENSIONS, In.										SHIPPING WGT., Lbs.
		A	B	C	D	F	G	H	J	K	L	
I-1284-B	2"	15	6	1/2	8-5/8	4	3/4	4-3/4	5-3/16	8	6-1/2	62
I-1284-C	2 1/2"	16-3/4	7	9/16	10	4	3/4	5-1/2	6-1/2	10	7-1/8	72
I-1284-D	3"	17	7-1/2	5/8	10-1/2	4	3/4	6	6-3/4	12	7-1/4	82
I-1284-E	4"	18-3/16	9	11/16	15-7/8	8	3/4	7-1/2	8-9/16	14	11-1/4	144
I-1284-F	5"	25-1/4	10	3/4	19-1/4	8	7/8	8-1/2	11-5/8	16	13-1/2	220
I-1284-G	6"	27-1/2	11	13/16	23-1/2	8	7/8	9-1/2	13-7/16	18	15-1/2	280

INSTALLATION

General

Prior to installation, the valve body and parts should be checked to determine if any damage occurred in shipment. Any damage should be reported to the shipper as soon as possible. Foreign matter which may have entered the valve during packing or shipment should be removed.

Location

The I-1284 may be installed indoors or out, provided the liquid to be controlled does not freeze. Temperature regulators should be installed as near as possible to the unit being controlled, and a pipeline strainer should be installed upstream. Position

Although these valves will operate in any position, the best performance is achieved in the vertical position (E port down). When the four, five, or six inch regulators are to be installed up-side-down, the factory should be

notified so that a special load spring may be supplied. (See Parts List.)

Service

Unless otherwise specified on the order, regulators are shipped with a general purpose split "O"-ring installed which is color-coded with one red dot. If the regulator is to be used on lube oil service, the lube oil split "O"-ring (color coded with two blue dots), that is attached to the valve, should be installed.

Whenever synthetic* lube oils or special coolants are used, the factory should be consulted to determine compatibility with split "O"-ring material.

*Not recommended for use with ester base synthetic lubricant.

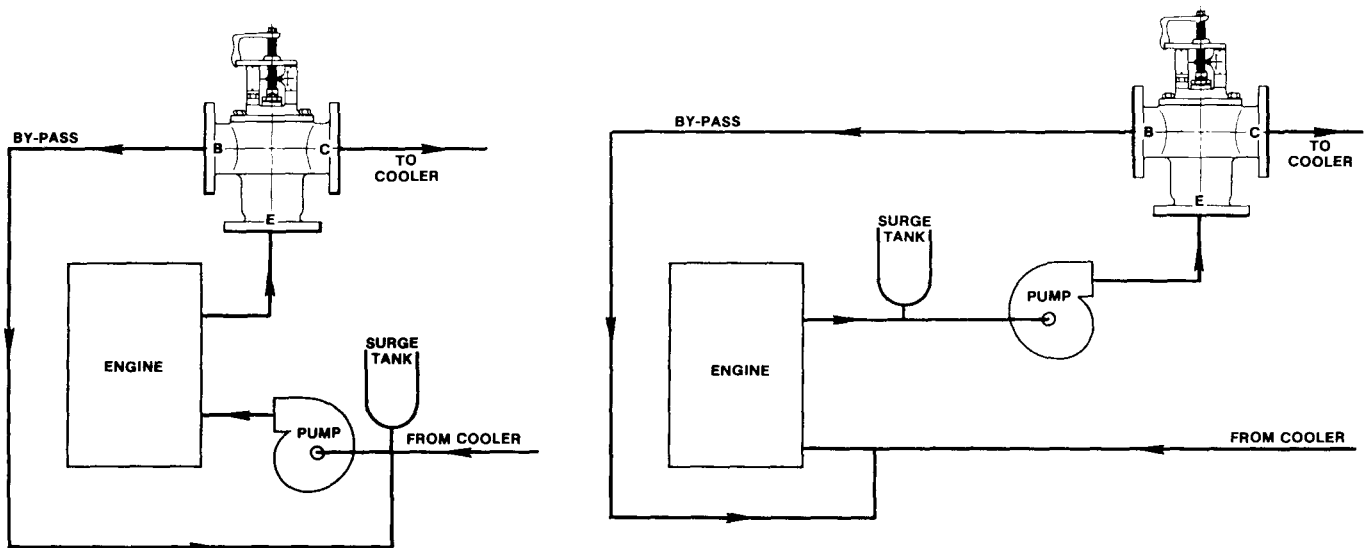

TYPICAL PIPING SCHEMATICS - USED AS DIVERTING VALVE TO CONTROL TEMPERATURE LEAVING ENGINE: PREFERRED AND MOST COMMON APPLICATIONS

Figure 2

OPERATION

With low temperature liquid surrounding the Power-Pill®, the poppet is in the upward position which connects ports "E" and "B." As the temperature increases, the Power-Pill® stem extends forcing the poppet downward. When the temperature reaches the control point of the regulator, the valve will be at mid-stroke. If the temperature continues to increase, the poppet will continue to move downward until the by-pass port (B) is

completely closed off. (See Figure 4.)

On the I-1284 a manual crank is provided to override Power-Pill® control. Turning the crank counterclockwise moves the poppet upward to close the "C" port. The "B" port may be closed by turning the crank clockwise. In event of Power-Pill failure, the crank should be turned clockwise until the desired cooling is achieved.

FLOW COEFFICIENTS: Table below indicates the flow in U.S. g.p.m. at different pressure drops. C_v Coefficients are listed in column 1 under .069 bar (1 psi) pressure drop (water).

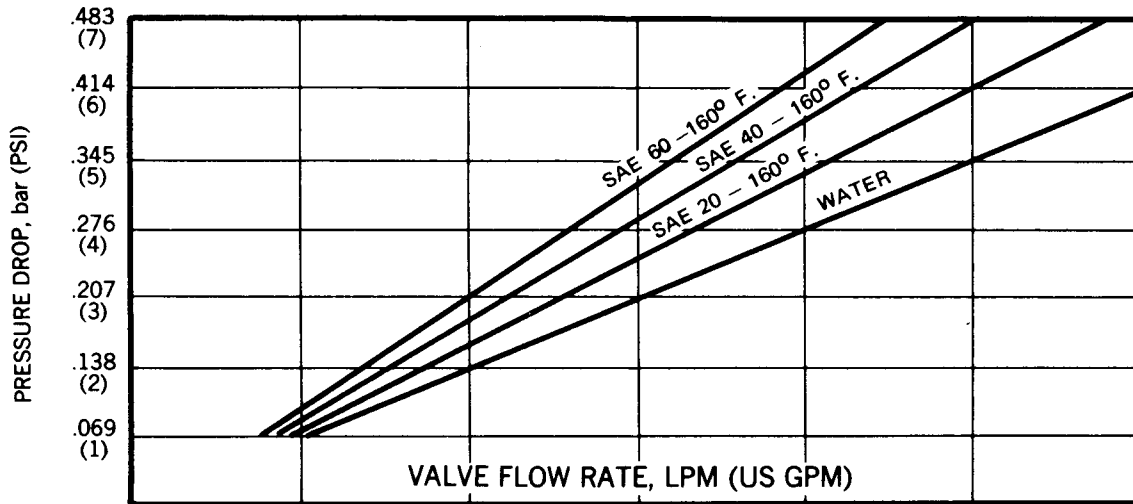

SIZE PORT		▲		▲		▲		▲		▲			
2"	C - Cooler Port	242	(64)	345	(91)	416	(110)	488	(129)	545	(144)	598	(158)
	B - Bypass Port	242	(64)	341	(90)	420	(111)	485	(128)	541	(143)	594	(157)
	E - Mid Stroke	310	(82)	439	(116)	538	(142)	621	(164)	693	(183)	761	(201)
2 1/2"	C - Cooler Port	333	(88)	473	(125)	575	(152)	666	(176)	746	(197)	814	(215)
	B - Bypass Port	307	(81)	435	(115)	530	(140)	613	(162)	685	(181)	749	(198)
	E - Mid Stroke	386	(102)	435	(115)	670	(177)	776	(205)	867	(229)	946	(250)
3"	C - Cooler Port	405	(107)	572	(151)	704	(186)	810	(214)	920	(239)	992	(262)
	B - Bypass Port	439	(116)	621	(164)	761	(201)	878	(232)	984	(260)	1075	(284)
	E - Mid Stroke	428	(113)	712	(188)	878	(232)	1007	(266)	1124	(297)	1234	(326)
4"	C - Cooler Port	992	(262)	1401	(370)	1718	(454)	1983	(524)	2218	(586)	2426	(641)
	B - Bypass Port	920	(243)	1298	(343)	1594	(421)	1840	(486)	2056	(544)	2252	(595)
	E - Mid Stroke	1227	(324)	1730	(457)	2121	(561)	2453	(648)	2755	(725)	3005	(794)
5"	C - Cooler Port	1544	(408)	2180	(576)	2672	(706)	3089	(816)	3444	(911)	3785	(1000)
	B - Bypass Port	1378	(364)	1949	(515)	2388	(631)	2756	(728)	3085	(815)	3376	(892)
	E - Mid Stroke	1893	(500)	2676	(707)	3274	(865)	3785	(1000)	4239	(1120)	4637	(1225)
6"	C - Cooler Port	2324	(614)	3278	(866)	4012	(1060)	4648	(1228)	5204	(1375)	5696	(1505)
	B - Bypass Port	1968	(520)	2830	(735)	3407	(900)	3936	(1040)	4410	(1165)	4826	(1275)
	E - Mid Stroke	2650	(700)	3747	(990)	4580	(1210)	5299	(1400)	5942	(1570)	6510	(1720)

NOTE 1: C_v coefficients coincide with figures in first column.

NOTE 2: Data on "Mid Stroke" shows total flow through inlet with valve in mid position.

NOTE 3: Normally, for engine application, valve should be sized for total flow through cooler port, based on a pressure drop of .138 - .345 bar (2 - 5 psi) incl.

NOTE 4: Total leakage through seats and web, approximately 2% or less of total flow with O-Ring removed.

MAINTENANCE

WARNING: USE CARE WHEN DISASSEMBLING - SPRING FORCES PRESENT.

Recommended Spare Parts

The following parts should be kept on hand for maintenance purposes:

1. Split "O"-ring seal.
2. Replacement Power-Pills.
3. Bonnet gasket.
4. Stem packing.

Trouble Shooting

If valve fails to make required stroke as temperature exceeds control point, check for:

1. Foreign matter interfering with poppet travel.
2. Swollen or damaged split "O"-ring seal. (See Service," Page 3.)
3. Power-Pill failure.

If valve fails to return stroke as temperature drops below control point, check for:

1. Foreign matter interfering with poppet travel.
2. Swollen or damaged split "O"-ring seal. (See Service," Page 3.)
3. Damaged load spring.
4. Power-Pill failure.

Excessive internal leakage between ports:

1. Damaged or worn out split "O"-ring seal. (See Service," Page 3.)
2. Damaged or uneven valve seats.
3. Poppet not making complete stroke.

Repair

Replacing Power-Pill elements:

1. Remove bonnet and poppet assembly from valve and place on wooden blocks. (See Figure 3.)

2. Loosen the packing gland and remove the bonnet from the poppet assembly completely by turning the stem clockwise and removing crank.
3. Loosen the bolts on top of the poppet and remove the stem and retainer by lifting upward.
4. Power-Pills and overrun assemblies may now be removed.
5. Reassemble as shown in Figures 4 through 10, depending on valve size.

Replacing split "O"-ring seal:

1. Remove bonnet and lift out the entire poppet assembly.
2. Remove old split "O"-ring and replace with a new one. (See "Service," Page 3.)
3. Replace poppet assembly, taking care not to cut or pinch ring.

Adjusting the I-1284

1. Reassemble the poppet assembly, bonnet and frame.
2. Reset the bottom of the poppet on blocks. (See Figure 3.)
3. Turn crank clockwise until bonnet seating surface just lifts off seating surface.
4. Turn the crank counterclockwise one-half to one turn so that the poppet is securely seated.
5. Set indicator at "thermostatic" on indicator plate and tighten nuts.
6. Complete assembly is now ready to install in valve body.

Repair Parts

For replacement part numbers, consult the parts list, pages 6 and 7. When ordering give complete model number, spare part name and number, with quantity required.

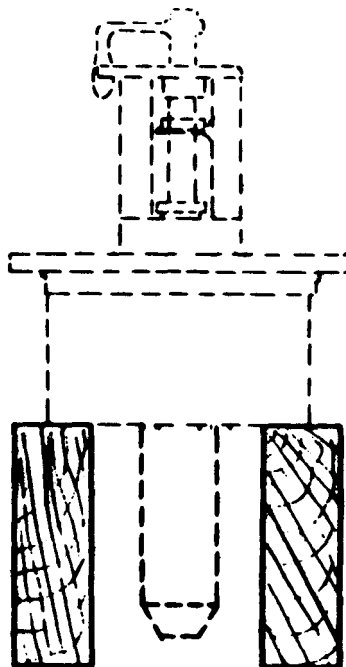

Figure 3

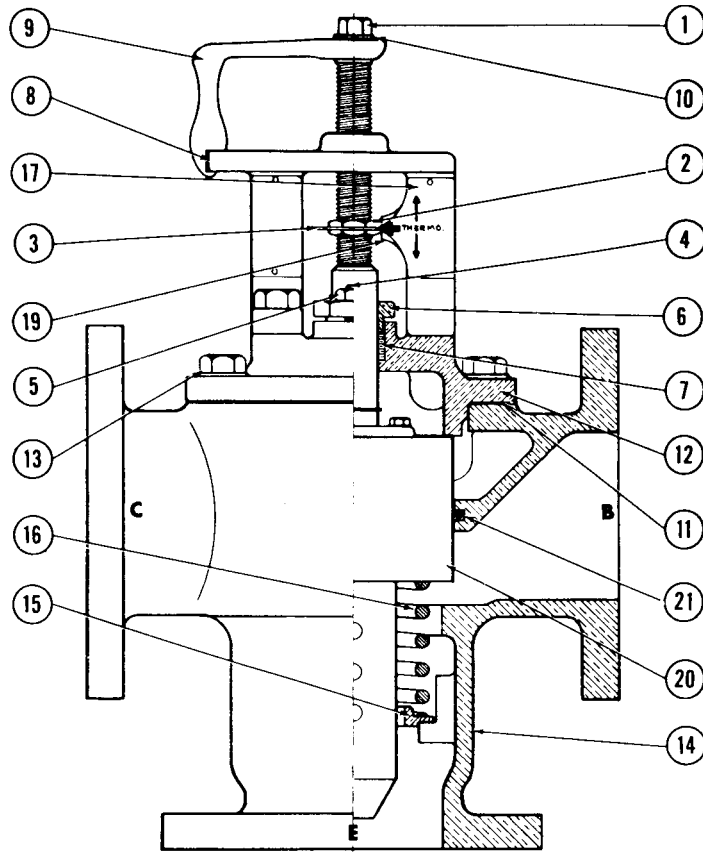

Figure 4

DETAIL NO.	DESCRIPTION	No. Req'd	I-1284-B 2"	No. Req'd	I-1284-C 2 1/2"	No. Req'd	I-1284-D 3"	No. Req'd	I-1284-E 4"	No. Req'd	I-1284-F 5"	No. Req'd	I-1284-G 6"
1	Cap Screw	1	36617-E1300	1	36617-E1300	1	36617-E1300	1	36617-E1300	1	36617-E1300	1	36617-E1300
2	Nut	2	22785	2	22785	2	22785	2	22785	2	22785	2	22785
3	Indicator	1	22786	1	22786	1	22786	1	22786	1	22786	1	22786
4	Packing Stud	2	19877	2	19877	2	19877	2	19877	2	19877	2	19877
5	Packing Nut	2	36602-E2201	2	36602-E2201	2	36602-E2201	2	36602-E2201	2	36602-E2201	2	36602-E2201
6	Packing Gland	1	19868	1	19868	1	19868	1	19868	1	19868	1	19868
7	Packing	5	25035-A1	5	25035-A1	5	25035-A1	5	25035-A1	5	25035-A1	5	25035-A1
8	Crank Frame	1	22808	1	22808	1	22808	1	22808	1	20079-B1	1	20079-B1
9	Crank	1	10670-A1	1	10670-A1	1	10670-A1	1	10670-A1	1	10670-A1	1	10670-A1
10	Washer	1	8237	1	8237	1	8237	1	8237	1	8237	1	8237
11	Gasket	1	39385-D3	1	39385-D3	1	39385-D3	1	39385-E2	1	39385-E5	1	39385-E5
12	Bonnet	1	19964	1	19964	1	19964	1	19859	1	20078	1	20078
13	Cap Screw	6	36625-B2423	6	36625-B2423	6	36625-B2423	10	36625-B2423	10	36625-B2423	10	36625-B2423
14	Valve Body	1	19990	1	20115	1	19966	1	30983-A1	1	20135	1	20068
15	Spring Retainer	1	31105-D1	1	31105-D1	1	31105-D1	1	31105-D1	1	31105-B1	1	31105-B1
*16	Load Spring	1	19983-A1	1	19863-A1	1	19863-A1	1	19863-A1	1	30989-B1	1	30989-B1
17	Indicator Plate (Shown)	1	19874-B 1	1	19874-B1	1	19874-B 1	1	19874-B 1	1	19874-B1	1	19874-B1
18	Indicator Plate (Back Side)	1	19875-B1	1	19875-B1	1	19875-B1	1	19875-B1	1	19875-B1	1	19875-B1
19	Flat Spring	1		1		1		1		1		1	
20	Poppet Assy.	1	See Fig.5 & Table 1	1	See Fig. 6 & Table 1	1	See Fig. 7 & Table 1	1	See Fig. 8 & Table 1	1	See Fig. 9 & Table 1	1	See Fig. 10 & Table 1
21	Split O-Ring General Purpose	1	24362-A2	1	24362-A2	1	24362-A2	1	24362-A2	1	24361-A2	1	24361-A2
*Springs for inverted valve service								1	28211-B1	1	28208-B1	1	28208-B1

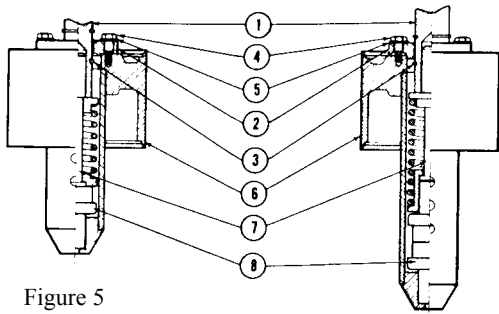

Figure 5
2" Size

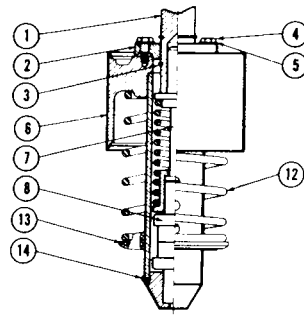

Figure 6
2 1/2" Size

Figure 7
3" Size

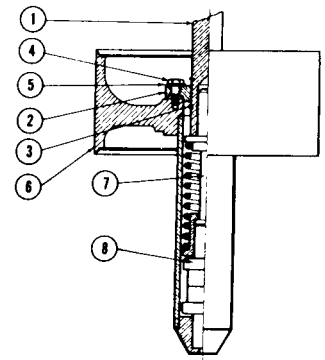

Figure 8
4" Size

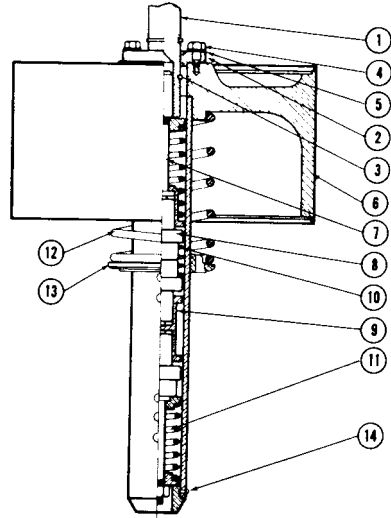

Figure 9
5" Size

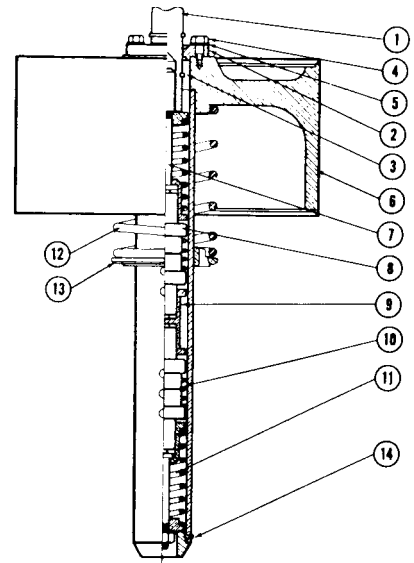

Figure 10
6" Size

Table 1

DETAIL NO.	DESCRIPTION	No. Req'd	I-1284-B 2"	No. Req'd	I-1284-C 2 1/2"	No. Req'd	I-1284-D 3"	No. Req'd	I-1284-E 4"	No. Req'd	I-1284-F 5"	No. Req'd	I-1284-G 6"
†All	Complete Poppet Assembly	1	82161-E	1	82161-F	1	82161-G	1	82161-N	1	82161-C	1	82161-D
1	Stem	1	30559-D1	1	23075-A1	1	30559-E1	1	30559-A1	1	30559-B1	1	30559-C1
2	Retainer	1	30524-B1	1	30524-B1	1	30524-B1	1	30524-A1	1	30524-A1	1	30524-A1
3	Retainer Ring	2	36605-J1	2	36605-J1	2	36605-J1	2	36605-J1	2	36605-J1	2	36605-J1
4	Cap Screw	3	36617-E1504	3	36617-E1504	3	36617-E1504	4	36617-E1504	4	36617-E1504	4	36617-E1504
5	Lock Washer	3	36600-L0912	3	36600-L0912	3	36600-L0912	4	36600-L0912	4	36600-L0912	4	36600-L0912
6	Poppet and Pipe Assembly	1	82159-C1	1	82159-C2	1	82159-C2	1	82159-A1	1	82159-B1	1	82159-B2
7	Top Spring and Stem Assembly	1	82158-B1	1	82158-A1	1	82158-A1	1	82158-A1	1	82158-A1	1	82158-A1
†8	Thermo Assembly	1	96995-A	2	96995-A	2	96995-A	2	96995-A	3	96995-A	4	96995-A
9	Spacer									1	30722-A1	1	30722-A1
10	Spring									1	20070-A1	2	20070-A1
11	Bottom Spring and Stem Assembly									1	82158-C1	1	82158-D1
*12	Load Spring					1	19863-A1	1	19863-A1	1	30989-B1	1	30989-B1
13	Spring Retainer					1	31105-D1	1	31105-D1	1	31105-B1	1	31105-B1
14	Drive Screw					1	25033-A1	1	25033-A1	1	25033-A1	1	25033-A1
*Springs for inverted valve service										1	28208-B1	1	28208-B1

† Add suffix number to Thermo Assembly and/or Poppet Assembly per range code on Page 1.

EXAMPLE: Thermo Assembly 96995-A11 for 165° F. setpoint.

Robertshaw

INDUSTRIAL PRODUCTS DIVISION

TEMPERATURE REGULATOR

I-1284-P, Q, S, T Series

General Description

The I-1284-P, Q, S & T Series Temperature Regulators are compact, self-contained and self-powered, three-way control valves especially adaptable to control of water and lubricating oil temperatures on internal combustion engines. The POWER PILL® element, located inside the poppet assembly, responds to the temperature of the medium surrounding it and provides the force necessary to position the poppet as the temperature of the liquid passing through the valve changes. Temperature regulation is achieved by the proportional action of the three-way valve which varies the amount of medium through or bypassing the cooler to maintain the desired temperature. Operation of the POWER PILL elements is unaffected by pressure changes in the system.

The POWER PILLS are factory-set for the specified control temperature and are not manually adjustable. By exchange of POWER PILL elements, the operating temperature may be changed in a very simple manner. Since all internal parts lift out with the valve bonnet, it is not necessary to remove the valve from the piping.

The I-1284 series is equipped with a quick-acting manual operator which permits overriding the thermal element if and when abnormal load conditions are encountered in the system.

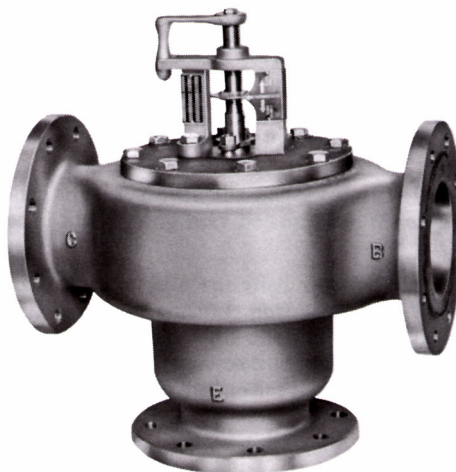

Specifications

A. CONSTRUCTION

Valve BodyCast steel with 150 lb. ANSI flanges.

Trim
 3" Brass poppet and seating surfaces.
 4, 5 & 6" Brass poppet with integral steel seating surfaces.

Packing Asbestos yarn Teflon* (suspensoid) treated rings.

Poppet Seal Split Buna-N "O"-ring (General Purpose, one red dot).

Dimensions - See Figure 2.

* Registered tradename of the Dupont Co.

B. OPERATING RANGES

Available temperature ranges are tabulated below. The maximum valve body rating is 150 psi at 250°F. **WARNING: DO NOT EXCEED MAXIMUM TEMPERATURE/PRESSURE RATING.**

C. MODELS AVAILABLE*

MODEL NO.		NORMAL OPERATING TEMPERATURE AT MID-STROKE, °F.			
		STANDARD		SPECIAL	
CODE	SIZE	CODE	TEMP.	CODE	TEMP.
P	3"	18	120	24	60
Q	4"	1	130	16	75
S	5"	15	140	22	80
T	6"	4	150	20	90
		5	155	19	100
		10	160	25	110
		11	165	2	135
		12	170		
		21	175		
		13	180		
		8	185		
		17	190		
		23	200		

*NOTE: For cast brass valve body, refer to I-1284-B thru G Series.

Installation

A. GENERAL

Prior to installation, the valve body and parts should be checked to determine if any damage occurred in shipment. Any damage should be reported to the shipper as soon as possible. Foreign matter which may have entered the valve during packing or shipment should be removed.

B. LOCATION

The I-1284 may be installed indoors or out, provided the liquid to be controlled does not freeze. Temperature regulators should be installed as near as possible to the unit being controlled, and a pipeline strainer should be installed upstream.

C. POSITION

Although these valves will operate in any position, the best performance is achieved in the vertical upright position (E port down). When the

four, five, or six inch regulators are to be installed up-side-down, the factory should be notified so that a special load spring may be supplied. (See Parts List).

D. SERVICE

Unless otherwise specified on the order, regulators are shipped with a general purpose split "O"-ring installed which is color coded with one red dot. If the regulator is to be used on lube oil service, the lube oil split "O"-ring (color coded with two blue dots), that is attached to the valve, should be installed.

Whenever synthetic* lube oils or special coolants are used, the factory should be consulted to determine compatibility with split "O"-ring material.

*Not recommended for use with ester base synthetic lubricant.

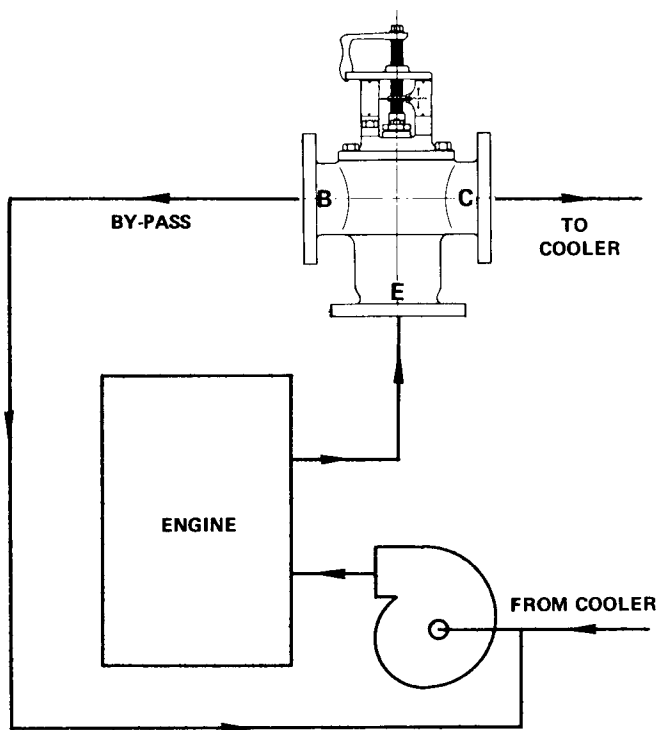

PIPING SCHEMATIC - USED AS DIVERTING VALVE TO CONTROL TEMPERATURE LEAVING ENGINE: MOST COMMON APPLICATION.

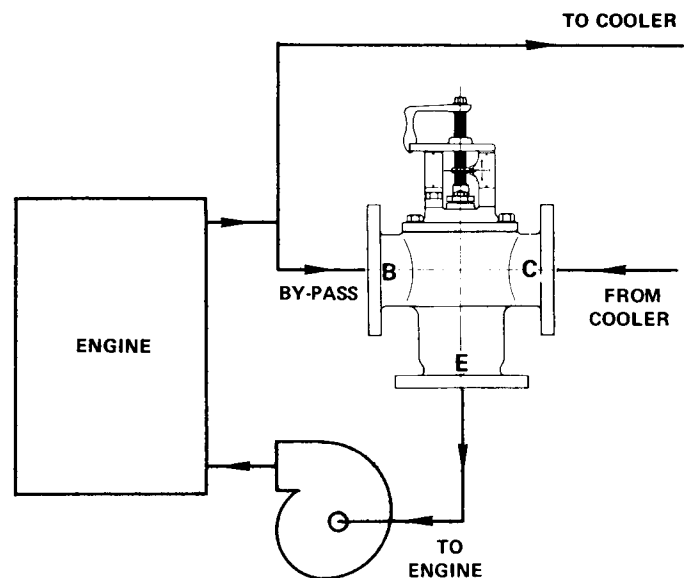

PIPING SCHEMATIC - USED AS BLENDING VALVE TO CONTROL TEMPERATURE ENTERING ENGINE.

Figure 1

Operation

With low temperature liquid surrounding the POWER PILL, the poppet is in the upward position which connects ports "E" and "B." As the temperature increases, the POWER PILL stem extends forcing the poppet downward. When the temperature reaches the control point of the regulator, the valve will be at mid-stroke. If the temperature continues to increase, the poppet will continue to move downward until the by-pass port (B) is completely closed off. (See Figure 4.)

On the I-1284 a manual crank is provided to override POWER PILL control. Turning the crank counterclockwise moves the poppet upward to close the "C" port. The "B" port may be closed by turning the crank clockwise. In event of power pill failure, the crank should be turned clockwise until the desired cooling is achieved.

FLOW COEFFICIENTS: Table below indicates the flow in U.S. G.P.M. at different pressure drops. C_v Coefficients are listed in column 1 under 1 psi pressure drop (water).

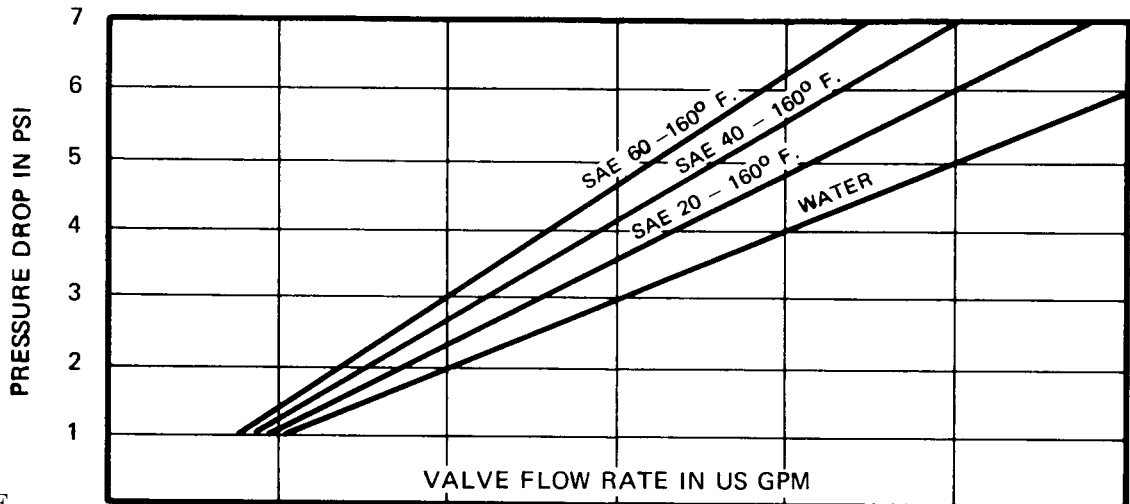

PORT SIZE

3"	C - Cooler Port	107	151	188	214	239	262
	B - Bypass Port	116	164	201	232	260	284
	E - Mid Stroke	113	188	232	266	297	326
4"	C - Cooler Port	262	370	454	524	586	641
	B - Bypass Port	243	343	421	486	544	595
	E - Mid Stroke	324	457	561	648	725	794
5"	C - Cooler Port	408	576	706	816	911	1000
	B - Bypass Port	364	515	631	728	815	892
	E - Mid Stroke	500	707	865	1000	1120	1225
6"	C - Cooler Port	614	866	1060	1228	1375	1505
	B - Bypass Port	520	735	900	1040	1165	1275
	E - Mid Stroke	700	990	1210	1400	1570	1720

NOTE 1: C_v coefficients coincide with figures in first column.

NOTE 2: Data on "Mid-Stroke" shows total flow through inlet with valve in mid position.

NOTE 3: Normally for engine application, valve should be sized for total flow through cooler port, based on a pressure drop of 2 - 5 psi (incl.)

NOTE 4: Total leakage through seats and web, approximately 2% or less of total flow with O-Ring removed.

Dimensions

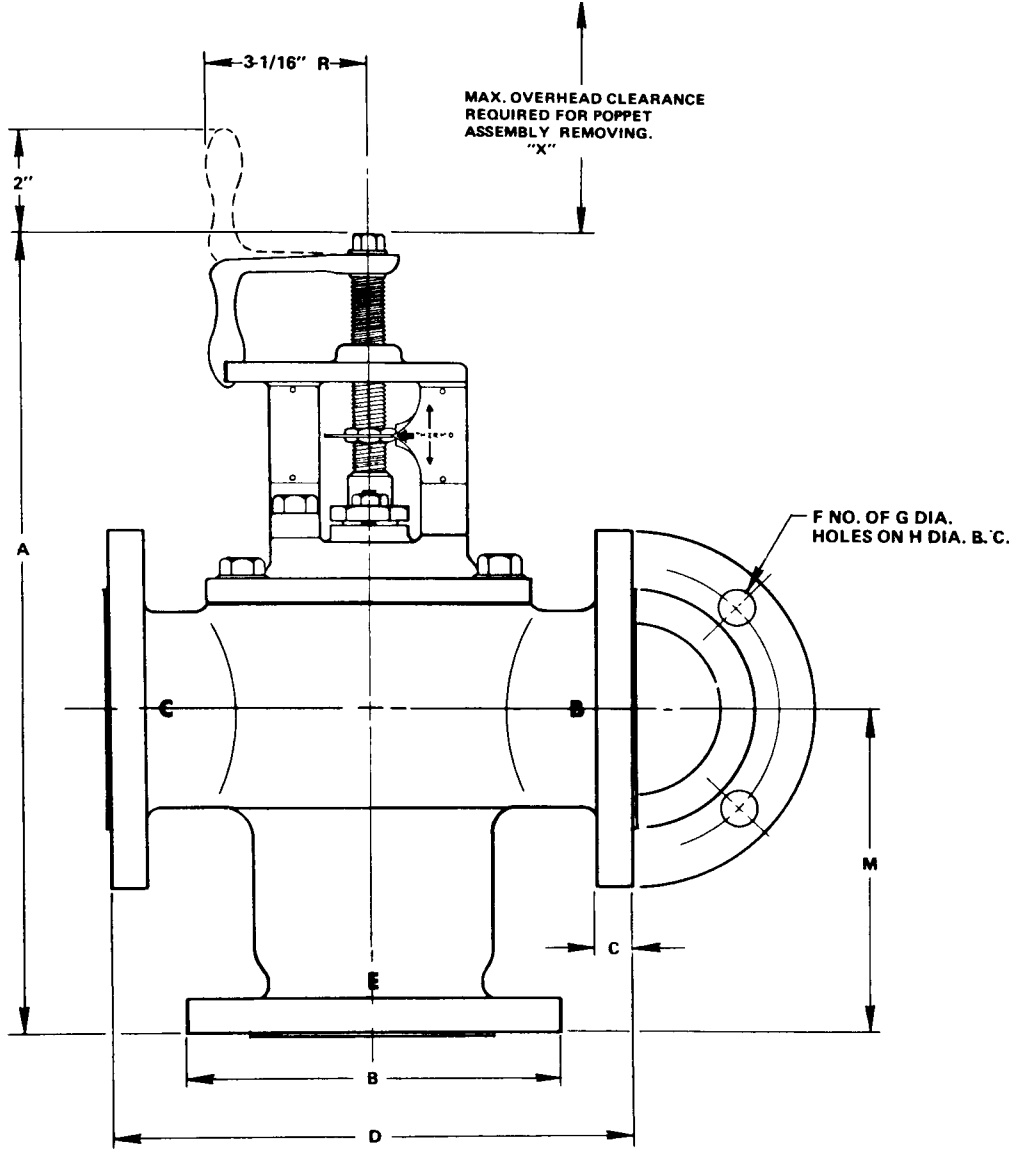

Figure 2

VALVE MODEL	SIZE, In.	DIMENSION								
		A	B	C	D	F	G	H	M	X
I-1284-P	3	16-1/2	7-1/2	13/16	10-1/2	4	3/4	6	6-3/4	12
I-1284-Q	4	18-9/16	9	15/16	15-7/8	8	3/4	7-1/2	8-9/16	14
I-1284-S	5	25-7/8	10	15/16	19-1/4	8	7/8	8-1/2	11-5/8	16
I-1284-T	6	28	11	1	23-1/2	8	7/8	9-1/2	13-7/16	18

Maintenance

A. RECOMMENDED SPARE PARTS

The following parts should be kept on hand for maintenance purposes:

1. Split "O"-ring seal.
2. Replacement power pills.
3. Bonnet gasket.
4. Stem packing.

B. TROUBLE SHOOTING

If valve fails to make required stroke as temperature exceeds control point, check for:

1. Foreign matter interfering with poppet travel.
2. Swollen or damaged split "O"-ring seal. (See "Service," Page 2.)
3. Power pill failure.

If valve fails to return stroke as temperature drops below control point, check for:

1. Foreign matter interfering with poppet travel.
2. Swollen or damaged split "O"-ring seal. (See "Service," Page 2.)
3. Damaged load spring.
4. Power pill failure.

Excessive internal leakage between ports:

1. Damaged or worn out split "O"-ring seal. (See "Service," Page 2.)
2. Damaged or uneven valve seats.
3. Poppet not making complete stroke.

C. REPAIR

WARNING: DISASSEMBLE CAREFULLY – SPRING LOAD FORCES PRESENT.

Replacing power pill elements:

1. Remove bonnet and poppet assembly from valve and place on wooden blocks. (See Figure 3.)
2. Loosen the packing gland and remove the bonnet from the poppet assembly completely by turning the stem clockwise and removing crank.
3. Loosen the bolts on top of the poppet and remove the stem and retainer by lifting upward.
4. Power pills and overrun assemblies may now be removed.
5. Reassemble as shown in Figures 4 through 7, depending on valve size.

Replacing split "O"-ring seal:

1. Remove bonnet and lift out the entire poppet assembly.
2. Remove old split "O"-ring and replace with a new one. (See Service," Page 2.)
3. Replace poppet assembly, taking care not to cut or pinch ring.

D. ADJUSTING THE I-1284

1. Reassemble the poppet assembly, bonnet and frame.
2. Rest the bottom of the poppet on blocks. (See Figure 3.)
3. Turn crank clockwise until bonnet seating surface just lifts off the poppet seating surface.
4. Turn the crank counterclockwise one-half to one turn so that the poppet is securely seated.
5. Set indicator at "thermostatic" on indicator plate and tighten nuts.
6. Complete assembly is now ready to install in valve body.

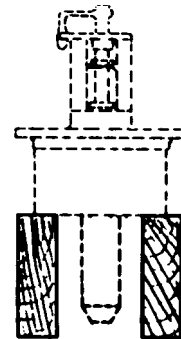

Figure 3

E. REPAIR PARTS

For replacement part numbers, consult the parts list, Pages 6 and 7. When ordering give complete model number, spare part name and number, with quantity required.

Ordering Information:

Specify Model No. including suffix.

Parts List

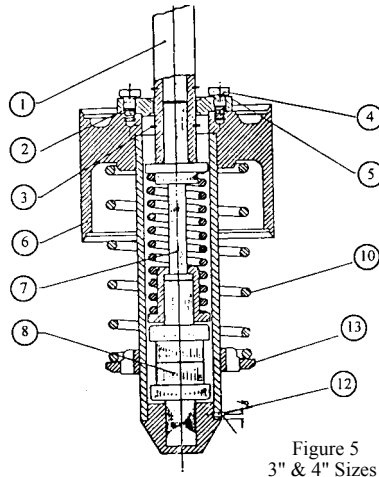

Figure 5
3\" & 4\" Sizes

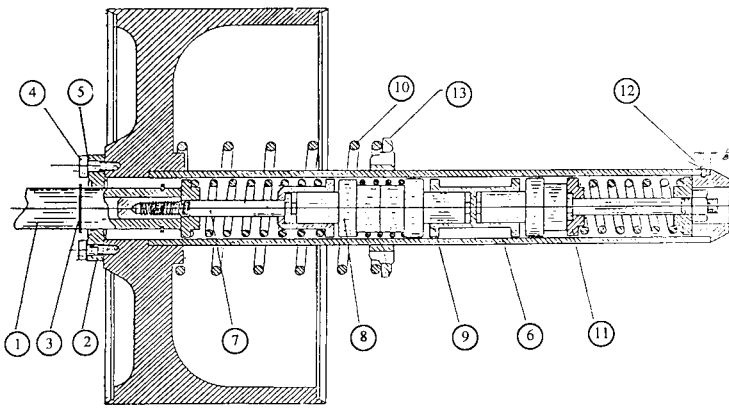

Figure 6
5\" Size

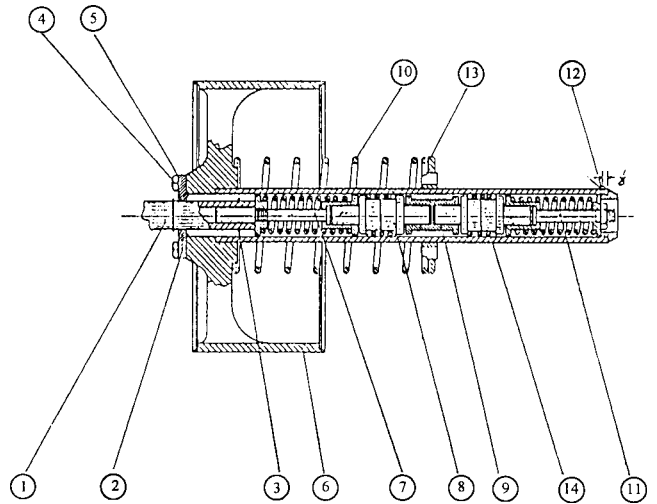

Figure 7
6\" Size

DETAIL NO.	DESCRIPTION	No. Req'd	I-1284-P 3"	No. Req'd	I-1284-Q 4"	No. Req'd	I-1284-S 5"	No. Req'd	I-1284-T 6"
*All	Complete Poppet Assembly	1	82161-L	1	82161-H	1	82161-K	11	82161-J
1	Stem	1	30559-J1	1	30559-F1	1	30559-H1	1	30559-G1
2	Retainer	1	30524-B1	1	30524-A1	1	30524-A1	1	30524-A1
3	Retainer Ring	2	36605-J1	2	36605-J1	2	36605-J1	2	36605-J1
4	Cap Screw	3	36617-E1504	4	36617-E1504	4	36617-E1504	4	36617-E1504
5	Lock Washer	3	36600-L0912	4	36600-L0912	4	36600-L0912	4	36600-L0912
6	Poppet & Pipe Assembly	1	82159-C2	1	82159-A1	1	82159-B1	1	82159-B2
7	Top spring & Stem Assy.	1	82158-A1	1	82158-A1	1	82158-A1	1	82158-A1
*8	Thermo. Assembly	2	96995-A	2	96995-A	3	96995-A	4	96995-A
9	Spacer					1	30722-A1	1	30722-A1
10	Spring	1	19863-A1	1	19863-A1	1	30989-B1	1	30989-B1
11	Bottom Spring & Stem Assy.					1	82158-C1	1	82158-D1
12	Drive Screw	1	25033-A1	1	25033-A1	1	25033-A1	1	25033-A1
13	Retainer, Spring	1	31105-D1	1	31105-D1	1	31105-B1	1	31105-B1
14	Spring					1	20070-A1	2	20070-A1

*Add suffix number to Thermo Assembly and /or Poppet Assembly per range code on Page 1.
EXAMPLE: Thermo Assembly 96995-A11 for 165°F. setpoint.

Parts List

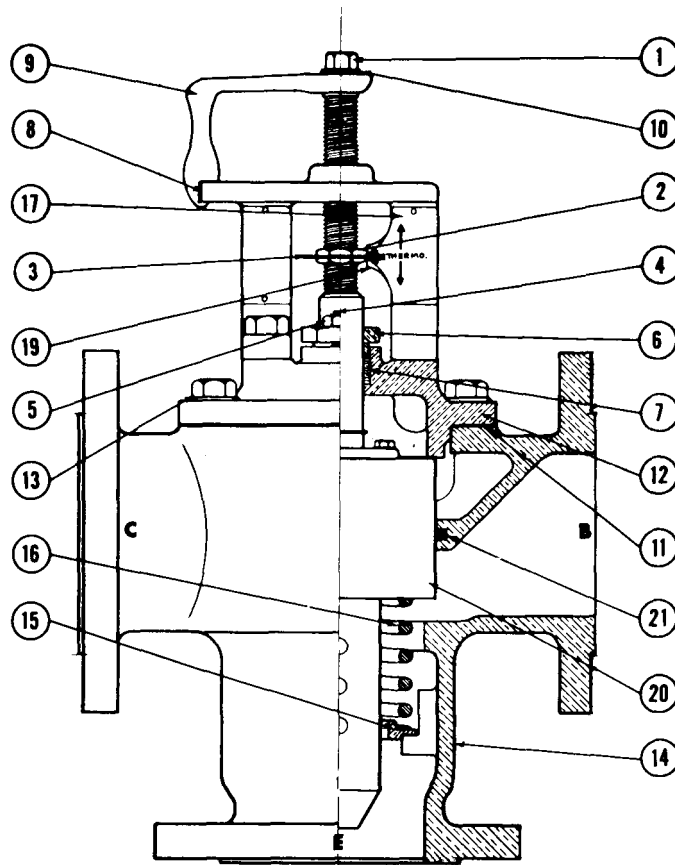

Figure 4

DETAIL NO.	DESCRIPTION	No. Req'd	I-1284-P 3"	No. Req'd	I-1284-Q 4"	No. Req'd	I-1284-S 5"	No. Req'd	I-1284-T 6"
1	Cap Screw	1	36617-E1300	1	36617-E1300	1	36617-E1300	1	36617-E1300
2	Nut	2	22785	2	22785	2	22785	2	22785
3	Indicator	1	22786	1	22786	1	22786	1	22786
4	Packing Stud	2	19877	2	19877	2	19877	2	19877
5	Packing Nut	2	36602-E2201	2	36602-E2201	2	36602-E2201	2	36602-E2201
6	Packing Gland	1	19868-B1	1	19868-B1	1	19868-B1	1	19868-B1
7	Packing	5	25035-A1	5	25035-A1	5	25035-A1	5	25035-A1
8	Crank Frame	1	22808	1	22808	1	20079-B1	1	20079-B1
9	Crank	1	10670-A1	1	10670-A1	1	10670-A1	1	10670-A1
10	Washer	1	8237	1	8237	1	8237	1	8237
11	Gasket	1	39385-F1	1	39385-F2	1	39385-F3	1	39385-F3
12	Bonnet	1	19964-B1	1	19859-B1	1	20078-B1	1	20078-B1
13	Cap Screw	4	36629-E2823	8	36629-E2823	8	36631-B3123	8	36631-B3123
14	Valve Body & Seat Ring	1	81710-B1	1	84867-A1	1	84867-A2	1	84867-A3
15	Spring Retainer	1	31105-D1	1	31105-D1	1	31105-B1	1	31105-B1
*16	Load Spring	1	19863-A1	1	19863-A1	1	30989-B1	1	30989-B1
17	Indicator Plate (Shown)	1	19874-B1	1	19874-B1	1	19874-B1	1	19874-B1
18	Indicator Plate (Back Side)	1	19875-B1	1	19875-B1	1	19875-B1	1	19875-B1
20	Poppet Assembly	1	See Fig. 5	1	See Fig. 5	1	See Fig. 6	1	See Fig. 7
21	Split O-Ring General Purpose	1	22777	1	22777-D1	1	22777-F1	1	22777-F1
*Springs for inverted valve service				1	28211-B	1	28208-B1	1	28208-B1